

AMW 423/IX

12NC: 858742301900

EAN code: 8003437394799

Whirlpool

SENSING THE DIFFERENCE

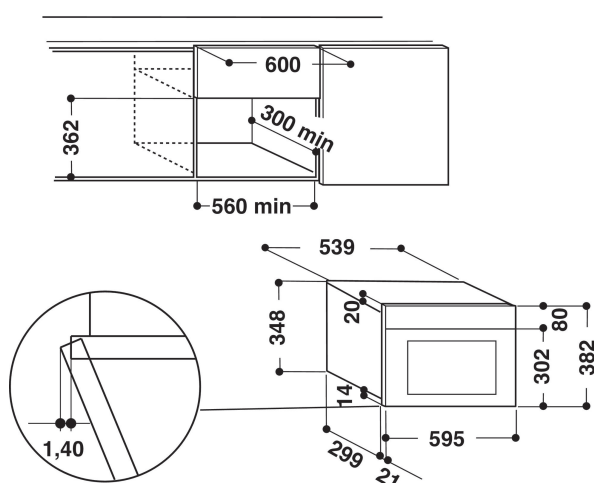

MAIN FEATURES

Product group	Microwave
Commercial code	AMW 423/IX
Main colour of product	Stainless steel
Type of micro-wave oven	MW only
Construction type	Vstavaná
Type of control	Electronic
Type of control setting and signalling devices	LED
Additional cooking method Grill	Nie
Crisp	Nie
Steam	Nie
Additional cooking method Fan cooking	Nie
Clock	Áno
Automatic programmes	Nie
Height of the product	382
Width of the product	595
Depth of the product	320
Minimum niche height	360
Minimum niche width	556
Niche depth	300
Net weight (kg)	21
Cavity capacity (l)	22
Turntable	Áno
Turntable diameter (mm)	250
Integrated Cleaning system	Nie

TECHNICAL FEATURES

Current (A)	10
Voltage (V)	230
Frequency (Hz)	50
Length of Electrical Supply Cord (cm)	135
Plug type	Nie
Timer	Minute minder
Grill power (W)	0
Type of grill	N/A
Cavity material	Painted
Interior light	Áno
Additional cooking method Grill	Nie
Position of interior lights	Right side

ENERGETICKÝ ŠTÍTK

6th Sense / Dynamic Intelligence	Nie
Number of power levels	4
Maximum micro-wave power (W)	750
Rozmrazovanie pečiva	Nie
Jet defrost	Áno
Jet start	Áno